



### **DIN 931 Hex Bolt**

Leader-Fastener is a manufacturer and distributor of **DIN 931 Hex Bolt**. We have a complete line of service from having invested in production plants, export department and to having a quality control team and center to meet your requirements. We regard quality as the life of the company. We persist in good quality as the first policy and have established a set of quality control and inspection system according to the international standard. We have carried out ISO9001 Quality Guarantee System in every course of production, transportation and selling. We do hope we could be your partner in business by topping quality, knight service and

competitive price in the near future and be your friends as well.

### **DIN 931 - Hexagon head bolts with shank**

Hexagon Bolts are created to DIN 931, and are a partially threaded fastener with a hexagon-shaped head that is usually fixed with a spanner or socket tool. Hosting a machine thread, these bolts are suitable for use with either a nut or within a pre-tapped hole. **DIN 931 Hex Head Bolts** have a hex head, external machine screw threads and are partially threaded with coarse threads. These externally wrenched bolts are used with nuts and internally threaded holes. Dimensionally similar to ISO 4014, they are available in Class 8.8, 10.9 and 12.9 steel; in stainless steel, most are Class 70 (A2-70, A4-70), some are Class 80 (A4-80) and some uncommon sizes may be Class 50. Zinc plating offers corrosion protection for steel while plain finish lacks a surface treatment to prevent rust. A2 stainless steel is equivalent to 18-8 and A4 is comparable to 316. Also referred to as hex head cap screws, minimum threaded length is based on bolt diameter and bolt length. Thread tolerance for Class 8.8 and 10.9 is 6g for plain finish and 6h for plated; it is 6g for stainless steel; right-hand threads are standard. Measure bolt length from under the head to the tip. **DIN 931 Hex Head Bolts** are similar to ISO 4014, JIS B1180 and ANSI B18.2.3.1M. Use DIN 933 if you need fully threaded or DIN 960 for partially threaded with fine threads. (Note: Thread pitch, which is the distance from thread to thread, is usually not specified for coarse threaded fasteners but is listed for reference.)

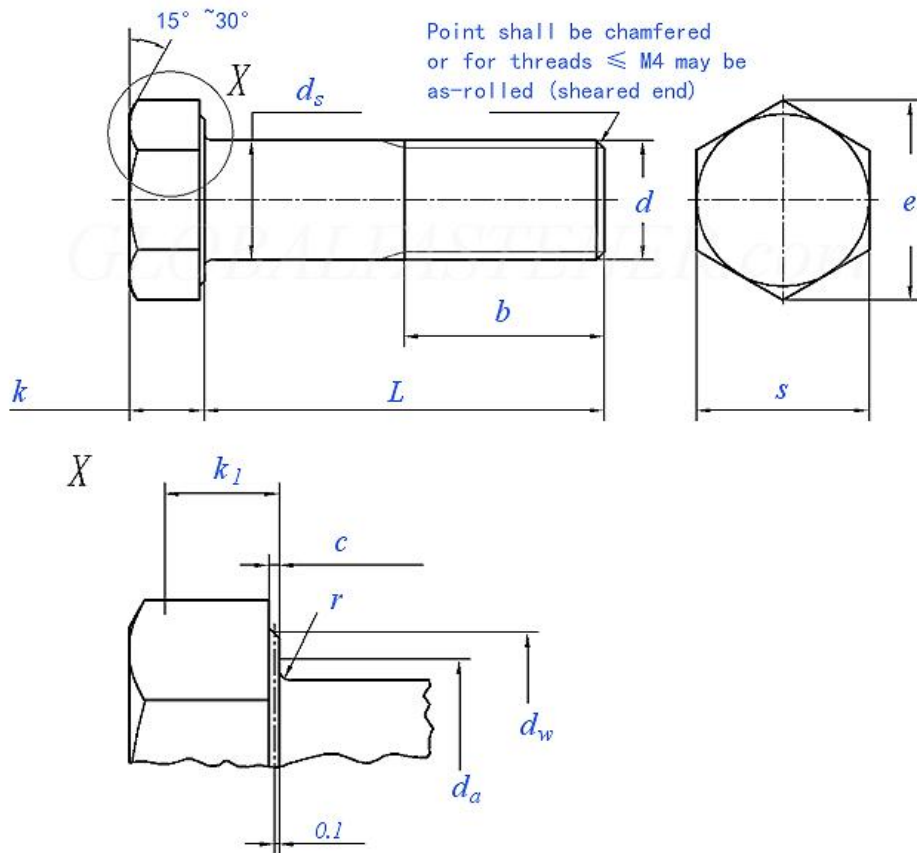
**DIN 931 Hex Bolt**

Thread Size d		M1.6	M2	M2.5	M3	(M3.5)	M4	M5	M6	(M7)	M8	M10	M12	
P	Thread Pitch	0.35	0.4	0.45	0.5	0.6	0.7	0.8	1	1	1.25	1.5	1.75	
b	Ref.	$L \leq 125$	9	10	11	12	13	14	16	18	20	22	26	30
		$125 < L \leq 200$	-	-	-	-	-	-	22	24	26	28	32	36
		$L > 200$	-	-	-	-	-	-	-	-	-	-	45	49
c	min	0.1	0.1	0.1	0.15	0.15	0.15	0.15	0.15	0.15	0.15	0.15	0.15	
	max	0.25	0.25	0.25	0.4	0.4	0.4	0.5	0.5	0.5	0.6	0.6	0.6	
$d_a$	max	2	2.6	3.1	3.6	4.1	4.7	5.7	6.8	7.8	9.2	11.2	13.7	
$d_s$	max=nominal size		1.6	2	2.5	3	3.5	4	5	6	7	8	10	12
	min	Grade A	1.46	1.86	2.36	2.86	3.32	3.82	4.82	5.82	6.78	7.78	9.78	11.73
		Grade B	-	-	-	-	-	-	-	-	-	-	-	-
$d_w$	min	Grade A	2.4	3.2	4.1	4.6	5.1	5.9	6.9	8.9	9.8	11.6	15.6	17.4
		Grade B	-	-	-	-	-	-	-	-	-	-	-	-
e	min	Grade A	3.41	4.32	5.45	6.01	6.58	7.66	8.79	11.05	12.12	14.38	18.9	21.1

	Grade B	-	-	-	-	-	-	-	-	-	-	-	-	
k	Nominal Size	1.1	1.4	1.7	2	2.4	2.8	3.5	4	4.8	5.3	6.4	7.5	
	Grade A	min	0.98	1.28	1.58	1.88	2.28	2.68	3.35	3.85	4.65	5.15	6.22	7.32
		max	1.22	1.52	1.82	2.12	2.52	2.92	3.65	4.15	4.95	5.45	6.58	7.68
	Grade B	min	-	-	-	-	-	-	-	-	-	-	-	-
		max	-	-	-	-	-	-	-	-	-	-	-	-
k <sub>1</sub>	min	0.7	0.9	1.1	1.3	1.6	1.9	2.28	2.63	3.19	3.54	4.28	5.05	
r	min	0.1	0.1	0.1	0.1	0.1	0.2	0.2	0.25	0.25	0.4	0.4	0.6	
s	max=nominal size	3.2	4	5	5.5	6	7	8	10	11	13	17	19	
	min	Grade A	3.02	3.82	4.82	5.32	5.82	6.78	7.78	9.78	10.73	12.73	16.73	18.67
		Grade B	-	-	-	-	-	-	-	-	-	-	-	-
Length of Thread b		-	-	-	-	-	-	-	-	-	-	-	-	

Thread Size d		(M14)	M16	(M18)	M20	(M22)	M24	(M27)	M30	(M33)	M36	(M39)	
P	Thread Pitch	2	2	2.5	2.5	2.5	3	3	3.5	3.5	4	4	
b	Ref.	L≤125	34	38	42	46	50	54	60	66	72	78	84
		125<L≤200	40	44	48	52	56	60	66	72	78	84	90
		L>200	53	57	61	65	69	73	79	85	91	97	103
c	min	0.15	0.2	0.2	0.2	0.2	0.2	0.2	0.2	0.2	0.2	0.3	
	max	0.6	0.8	0.8	0.8	0.8	0.8	0.8	0.8	0.8	0.8	1	
d <sub>a</sub>	max	15.7	17.7	20.2	22.4	24.4	26.4	30.4	33.4	36.4	39.4	42.4	
d <sub>s</sub>	max=nominal size	14	16	18	20	22	24	27	30	33	36	39	
	min	Grade A	13.73	15.73	17.73	19.67	21.67	23.67	-	-	-	-	-
		Grade B	-	15.57	17.57	19.48	21.48	23.48	26.48	29.48	32.38	35.38	38.38
d <sub>w</sub>	min	Grade A	20.5	22.5	25.3	28.2	30	33.6	-	-	-	-	-
		Grade B	-	22	24.8	27.7	29.5	33.2	38	42.7	46.6	51.1	55.9
e	min	Grade A	24.49	26.75	30.14	33.53	35.72	39.98	-	-	-	-	-
		Grade B	-	26.17	29.56	32.95	35.03	39.55	45.2	50.85	55.37	60.79	66.44
k	Nominal Size	8.8	10	11.5	12.5	14	15	17	18.7	21	22.5	25	
	Grade A	min	8.62	9.82	11.28	12.28	13.78	14.78	-	-	-	-	-
		max	8.98	10.18	11.72	12.72	14.22	15.22	-	-	-	-	-
	Grade B	min	-	9.71	11.15	12.15	13.65	14.65	16.65	18.28	20.58	22.08	24.58
		max	-	10.29	11.85	12.85	14.35	15.35	17.35	19.12	21.42	22.92	25.42
k <sub>1</sub>	min	5.96	6.8	7.8	8.5	9.6	10.3	11.7	12.8	14.4	15.5	17.2	
r	min	0.6	0.6	0.6	0.8	0.8	0.8	1	1	1	1	1	

s	max=nominal size	22	24	27	30	32	36	41	46	50	55	60	
	min	Grade A	21.67	23.67	26.67	29.67	31.61	35.38	-	-	-	-	-
		Grade B	-	23.16	26.16	29.16	31	35	40	45	49	53.8	58.8
Length of Thread b		-	-	-	-	-	-	-	-	-	-	-	

Screw Thread d	M4	(M4 5)	M4 8	(M5 2)	M5 6	(M6 0)	M64	(M68 )	M72	(M76 )	M80	M90	M10 0	M11 0	M12 5	M1 40	M1 60	
P Pitch	4.5	4.5	5	5	5.5	5.5	6	6	6	6	6	6	6	6	6	6	6	
b	L≤125	90	96	102	-	-	-	-	-	-	-	-	-	-	-	-	-	
	125<L≤200	96	102	108	116	124	132	140	148	156	164	172	192	-	-	-	-	
	L>200	109	115	121	129	137	145	153	161	169	177	185	205	225	245	275	305	345
c	min	0.3	0.3	0.3	0.3	-	-	-	-	-	-	-	-	-	-	-	-	
	max	1	1	1	1	1	1	1	1	1	2	2	2	2	2	2	2	
d <sub>a</sub> max	45.6	48.6	52.6	56.6	63	67	71	75	79	83	87	97	107	117	132	147	167	
d <sub>s</sub>	max=nominal size	42	45	48	52	56	60	64	68	72	76	88	90	100	110	125	140	160
	min	41.61	44.38	47.38	51.26	55.26	59.26	63.26	67.26	71.26	75.26	79.23	89.13	99.13	109.13	124	139	159
d <sub>w</sub> min	60.6	64.7	69.4	74.2	78.7	83.4	88.2	92.9	97.7	102.1	106.9	121.1	135.4	144.9	168.6	185.6	214.1	
e min	71.3	76.95	82.6	88.25	93.56	99.21	104.86	110.51	116.16	121.81	127.46	144.08	161.02	172.32	200.57	220.8	254.7	
k	Nominal Size	26	28	30	33	35	38	40	43	45	48	50	57	63	69	79	88	100
	max	26.42	28.42	30.42	33.5	35.5	38.5	40.5	43.5	45.5	48.5	50.5	57.6	63.6	69.6	79.6	88.7	100.7
	min	25.58	27.58	29.58	32.5	34.5	37.5	39.5	42.5	44.5	47.5	49.5	56.4	62.4	68.4	78.4	87.3	99.3
k <sub>1</sub> min	17.9	19.3	20.9	22.8	24.2	26.2	27.6	29.8	31.2	33.2	34.6	40.3	43.7	47.9	54.9	61.1	69.5	
r min	1.2	1.2	1.6	1.6	2	2	2	2	2	2	2	2.5	2.5	2.5	2.5	2.5	2.5	
s	max=nominal size	65	70	75	80	85	90	95	100	105	110	115	130	145	155	180	200	230
	min	63.1	68.1	73.1	78.1	82.8	87.8	92.8	97.8	102.8	107.8	112.8	127.5	142.5	152.5	177.5	195.4	225.4

Length of Thread b	-	-	-	-	-	-	-	-	-	-	-	-	-	-	-	-	-
--------------------	---	---	---	---	---	---	---	---	---	---	---	---	---	---	---	---	---

**Material:**

- a) Steel, Property class: 5.6,8.8,10.9 according to DIN ISO 898-1
- b) Stainless steel, Property class: ≤M20: A2-70,A4-70; > M20: A2-50, A4-50; C3, C4 according to DIN 267-11
- c) Non-ferrous metal according to DIN 267-18